



***The usage and maintain User's Guide
ONE-STEP shrink wrap machines***

Suitable for

PPG 1318 OS (FM-4030 & FM-4535)
PPG 1622 AOS (FM-5540A)



lease notice the marks hereunder when operating the machine

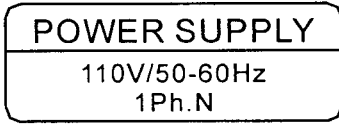

Power supply: 1 Phase 110V 50/60Hz

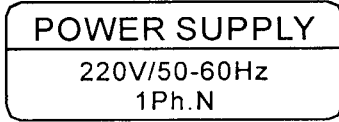

Power supply: 1 Phase 220V 50/60Hz

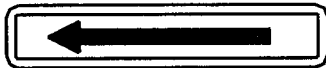

Direction of transportation and convey



Be cautious of the high temperature

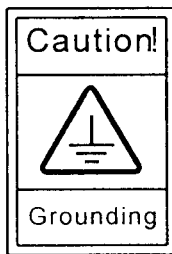

Warning! The machine must be earthed before use

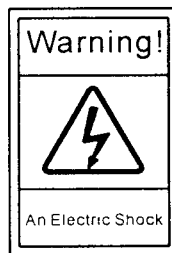

Warning! Unauthorized or non-professional personnel don't open it



Warning! Danger for injury or cutting to hand

Table of contents

1- Foreword	1
2- Machine dimension and crate dimension	3
3- Machine panel and each button name and function	5
4- Machine parts illuminate drawing	6
5-Machine technology parameter	12
6-Machine installation	13
7-Machine operation method	14
8-Machine maintenance	16
9-Machine circuit diagram	17
10- Troubleshooting	18
11-Packing list	18

1. Foreword

1-1 How to consult and use this manual

- A) Please read carefully and fully this manual before using this machine.
- B) This manual is an integral part of the machine and must always accompany the machine.
- C) This machine must be kept for as long as the machine is in the user's possession or, if that is the case, handed over to any other user or subsequent owner.
- D) Please keep this manual well without damage
- E) Please don't delete or modify any part or content in this manual without special authorization.
- F) The reset or adjustment to the technical parameter of the machine should be in compliance with the instruction of this manual.
- G) We reserve the right to make technical modification on this machine and on this manual in order to improve and perfect the quality and performance of the machine
- H) If you have any good suggestion for the machine and the manual, don't hesitate to contact us.

1-2 Remarks on general safety

- A) The breaker and wires applied must correspond to the capacity of the power supply of the machine. Otherwise, damage occurs to the parts or wiring if the smaller capacity breaker or the smaller diameter wires are applied.
- B) To guarantee the liquid would not leak out when packaging liquid product. If not, damage would be made to the machine and the operator would possibly get an electric shock.
- C) Don't use the machine in a very moist and humid environment, or a place full of a lot of vapor.
- D) Don't use the machine in a place full of dust.
- E) The sealing blade, ceramic grain and the heating tube are of high temperature, don't touch by your hand.
- F) Don't put any metal article on the part for sealing and cutting in order to avoid damage the sealing blade.
- G) The sealing time should be of 0.8-1.5 second in general, the sealing blade would be damaged if the sealing time to be set too long.

- H) The shrinking temperature would be of 300°C-350°C, the sealing blade would be damage if the shrinking time too long. The parts would be damaged and a bad packaging effect occurs if the shrinking temperature is too high.
- I) The sealing blade, teflon belt, neoprene rubber is easy to be worn after some time, so please prepare some damageable parts like these and examine and repair the machine periodically.

1-3 Summarization

Thanks for your choice of using our machine, so you have a safe, applied, efficient sealing and shrinking 2 in 1 packaging machine. We hope you will be satisfied with our machine and to be a long-term user of our product.

Features of the machine:

- A) This machine is widely used for the packaging application of these industries: food, toy, hardware, cosmetic, medicine, daily commodity, books, bamboo product, wooden product etc.
- B) Sealing and shrinking 2 in 1 step, take on small space and easy to operate.
- C) Applied to a variety of shrink film such as PVC, POF etc.
- D) The sealing blade is made of alloy, stick-proof and high temperature-proof, without carbonization and smoking when packaging. The sealing time is easy to be adjusted based on the thickness of the film.
- E) Stainless steel heating tube adopted and with the heat dissipate on the surface, increasing temperature fast and long life-span of usage.
- F) The models with automatic convey function (FM-4030A & FM-5540A), the product is unloaded automatically by the conveying belt and the transport time is adjustable.
- G) Seal and shrink for one time, safe and reliable, easy to operate, the part sealed on the film is firm and looks well.
- H) This machine can work continuously for a long time.

2. Machine dimension and crate dimension

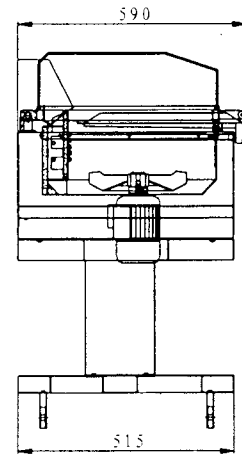
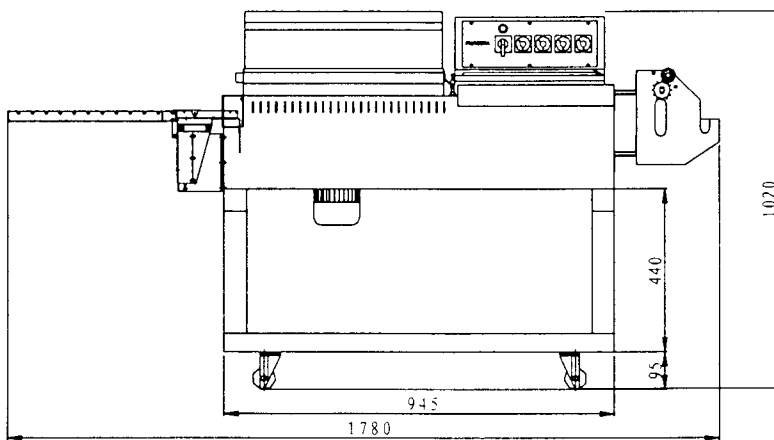
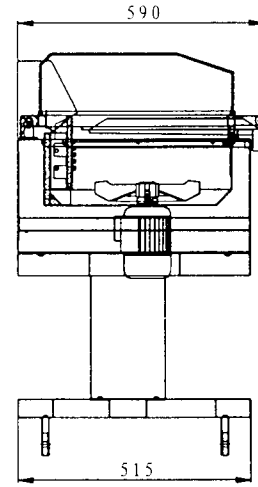
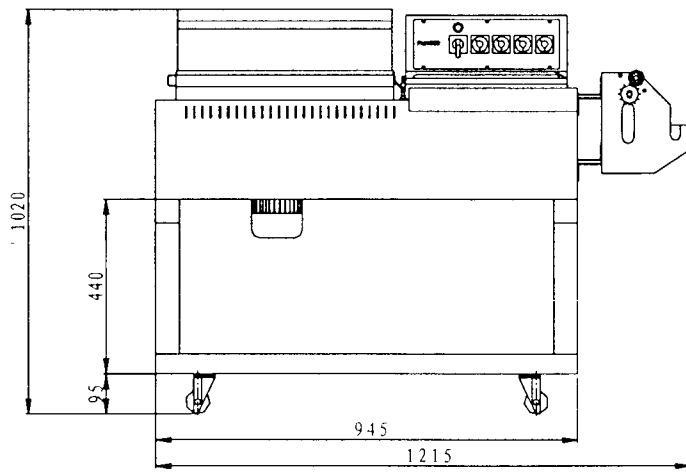
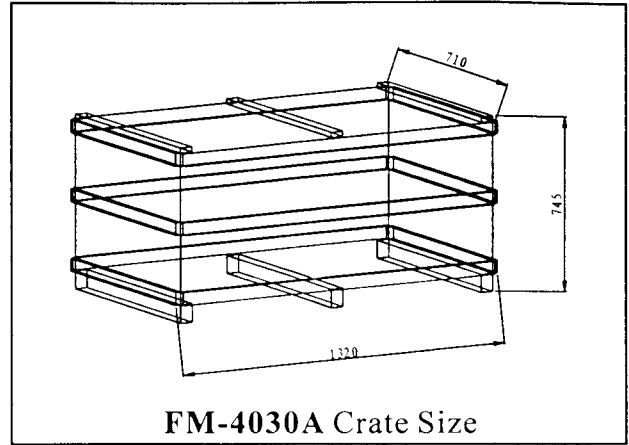
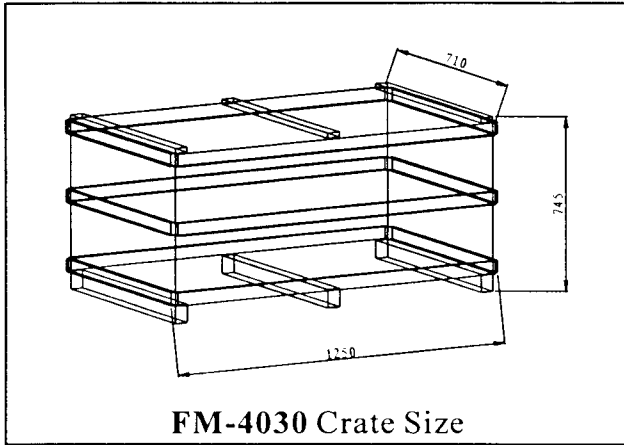

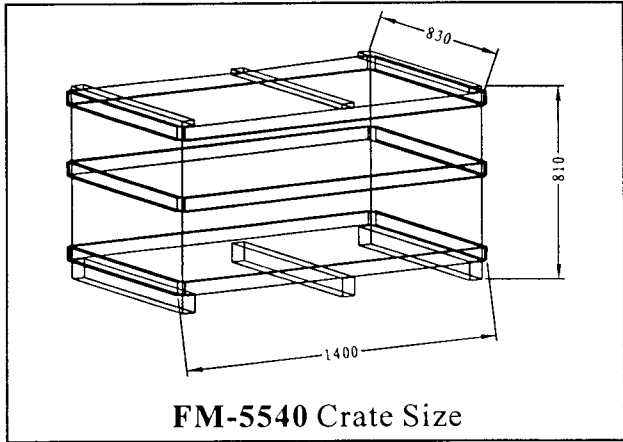

FM-5540 Crate Size

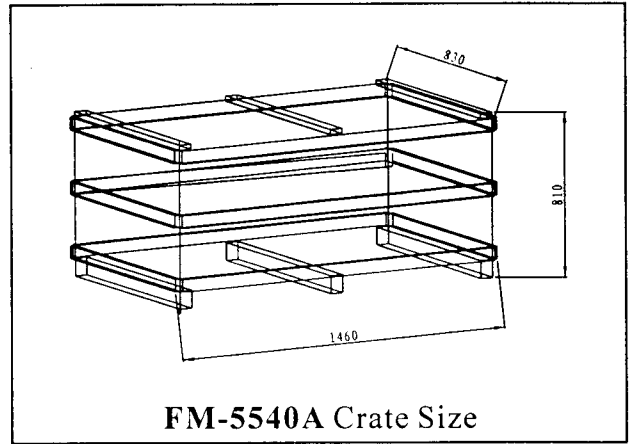

FM-5540A Crate Size

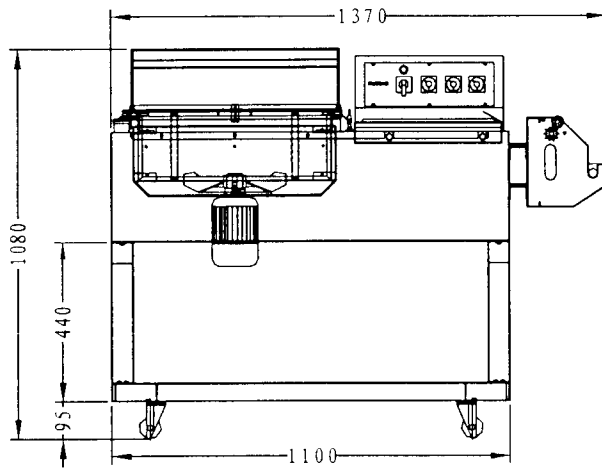

FM-5540 Machine Size

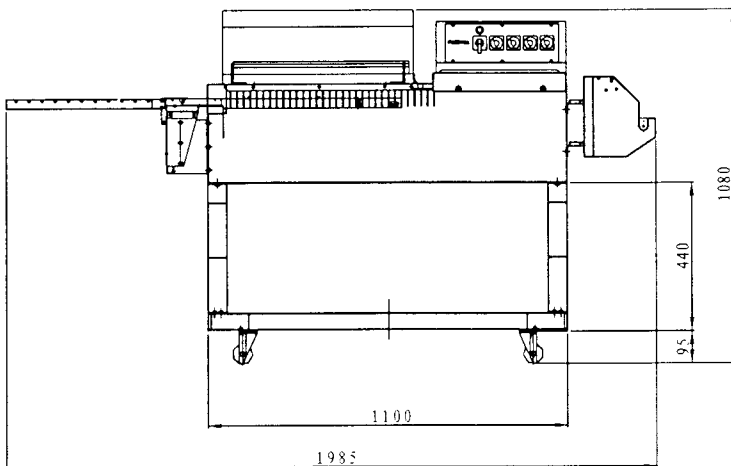
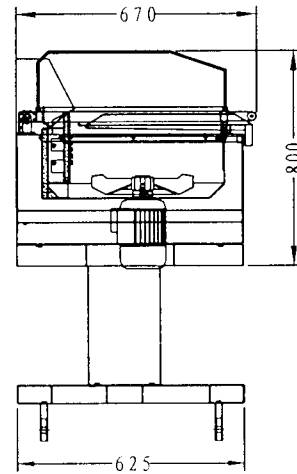

FM-5540A Machine Size

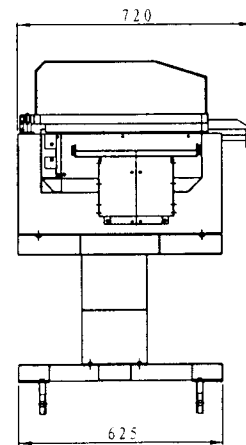

3. Machine panel and each button name and function

FM-4030/FM-5540 Control panel:

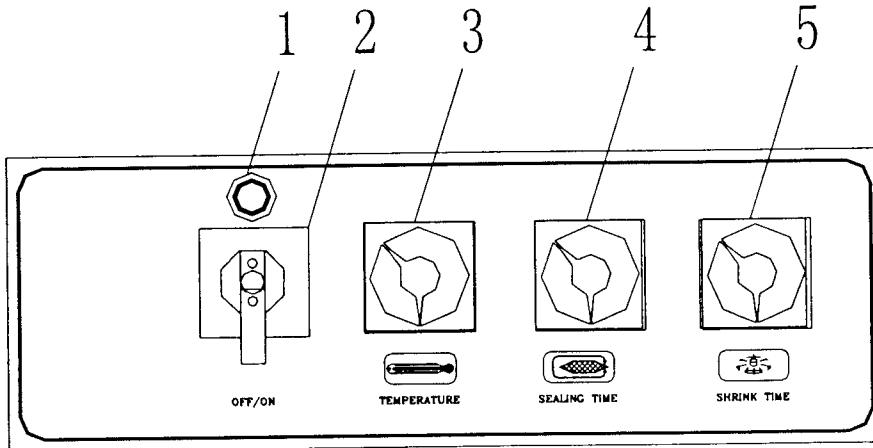

1. Power Indicator light: indicate that the if the power of the machine is on
2. Power switch: on or off the power of the machine
3. Shrinking temperature: set the temperature of heating system
4. Sealing time: set the heating time of the sealing blade
5. Blowing time: set the blowing time of the blowing fan

FM-4030A/FM-5540A Control panel:

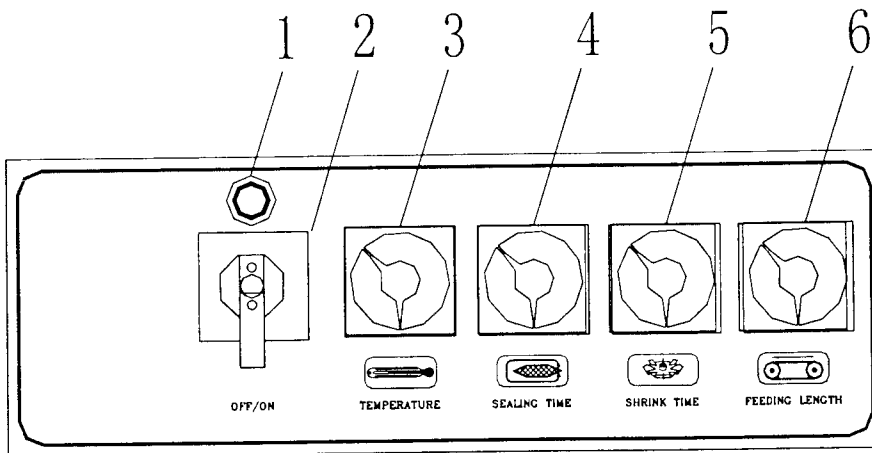

1. Power Indicator light: indicate that if the power of the machine is on
2. Power switch: on or off the power of the machine
3. Shrinking temperature: set the temperature of heating system
4. Sealing time: set the heating time of the sealing blade
5. Blowing time: set the blowing time of the blowing fan
6. Conveying time: set the conveying time of the transportation system

4. Machine parts illuminate drawing

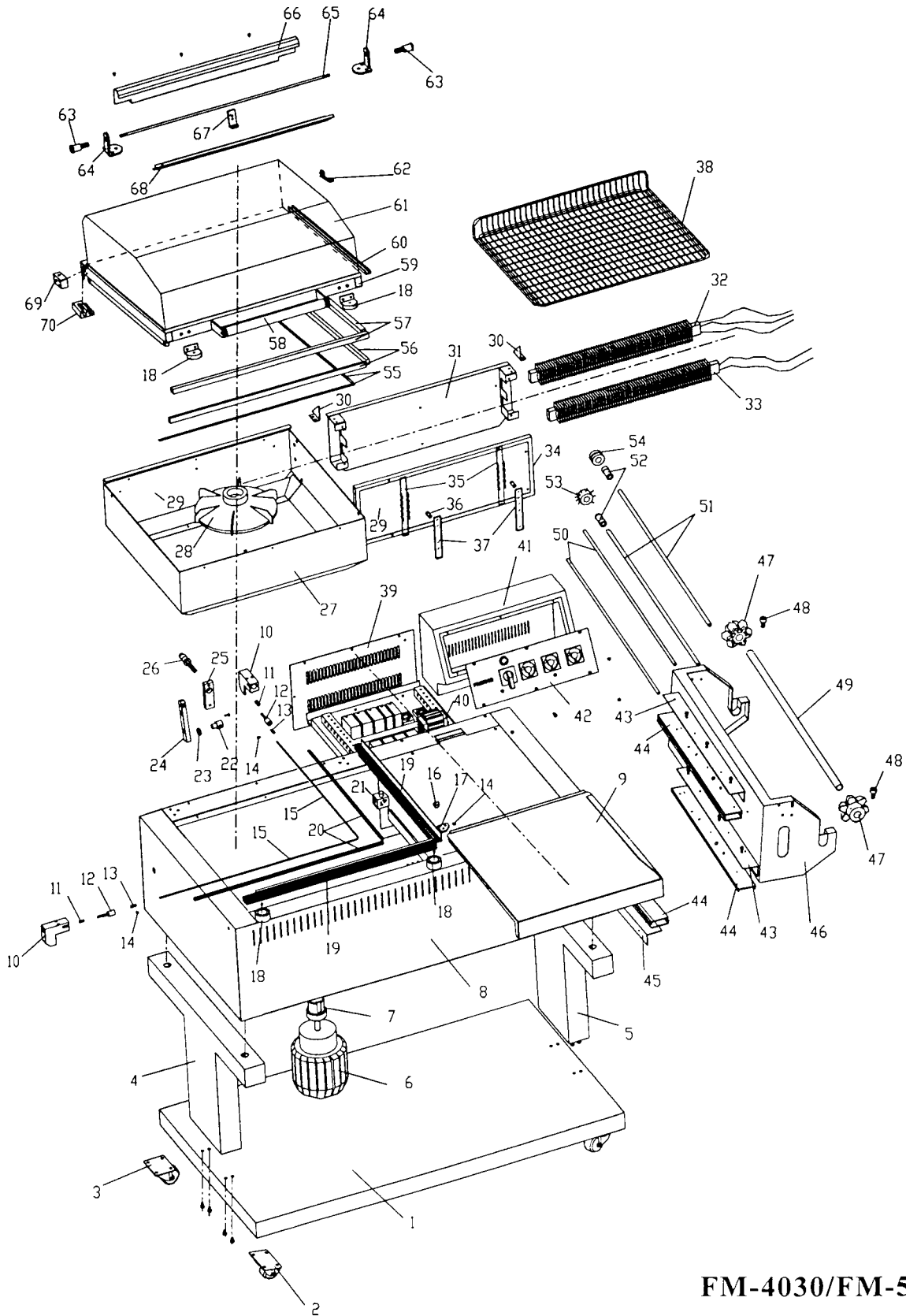

FM-4030/FM-5540

Use and Maintenance Manual
FM-4030/FM-4030A/FM-5540/FM-5540A

No.	Name	Quantity	No.	Name	Quantity
01	Baseplate	1	36	Adjusting screw of the net	2
02	Wheel (with lock)	2	37	Fixed board of the net	2
03	Wheel	2	38	Net	1
04	Left stand	1	39	Cover board of power distributing box	1
05	Right stand	1	40	Power distributing board	1
06	Blowing motor	1	41	Control box	1
07	The cover of the blowing fan shaft	1	42	Control panel	1
08	Main frame	1	43	Skid rail 1 for angle iron installation	2
09	Movable working table	1	44	Skid rail	2
10	The support of the blade clamp	2	45	Skid rail 2 for angle iron installation	2
11	The spring of the blade clamp	2	46	Reel holder	1
12	The cooper core of the blade clamp	2	47	Fixer	2
13	The iron core of the blade clamp	2	48	Fixing bolt for the fixer	2
14	The fixing bolt of the blade clamp	3	49	Shaft of reel	1
15	Sealing blade	1	50	Shaft for film stretching ahead	2
16	The corner of the blade clamp	1	51	Shaft of perforator	2
17	The corner pad of the blade clamp	1	52	Cover of the perforator wheel	2
18	Magnet	2	53	Pin wheel of the perforator	1
19	Ceramic grain base	2	54	Slot wheel of the perforator	1
20	Ceramic blade slot	2	55	Teflon belt	2
21	Jiggle switch	1	56	Neoprene rubber	4
22	The nut for adjusting the swing angle of the torsion bar	1	57	Slot of neoprene rubber	5
23	The retaining ring for adjusting the swing angle of the torsion bar	1	58	Handle	1
24	Adjusting pendulum of the torsion bar	1	59	Upper sealing frame	1
25	Adjusting base of the swing angle of the torsion bar	1	60	Aluminium slot for fixing the glass hood.	4
26	Adjusting bar of the swing angle of the torsion bar	1	61	Glass hood	1
27	Fan box	1	62	Press plate of the jiggle switch	1
28	Blowing fan	1	63	Hollow screw	2
29	Heat insulation cotton	2	64	Support plate of the torsion bar	symmetrical each other
30	The support of the left and right corners of the upper sealing frame	symmetrical each other	65	Torsion bar	1
31	The bracket of the heating tube	1	66	Secure cover of the torsion bar	1
32	Heating tube (with thermocouple)	1	67	The press plate of the open and close board	1
33	Heating tube	1	68	The open and close board	1
34	Heat insulation board	1	69	Fixer of the torsion bar	1
35	Pothead of the net	2	70	Restrictor of upper sealing	1

Use and Maintenance Manual
FM-4030/FM-4030A/FM-5540/FM-5540A

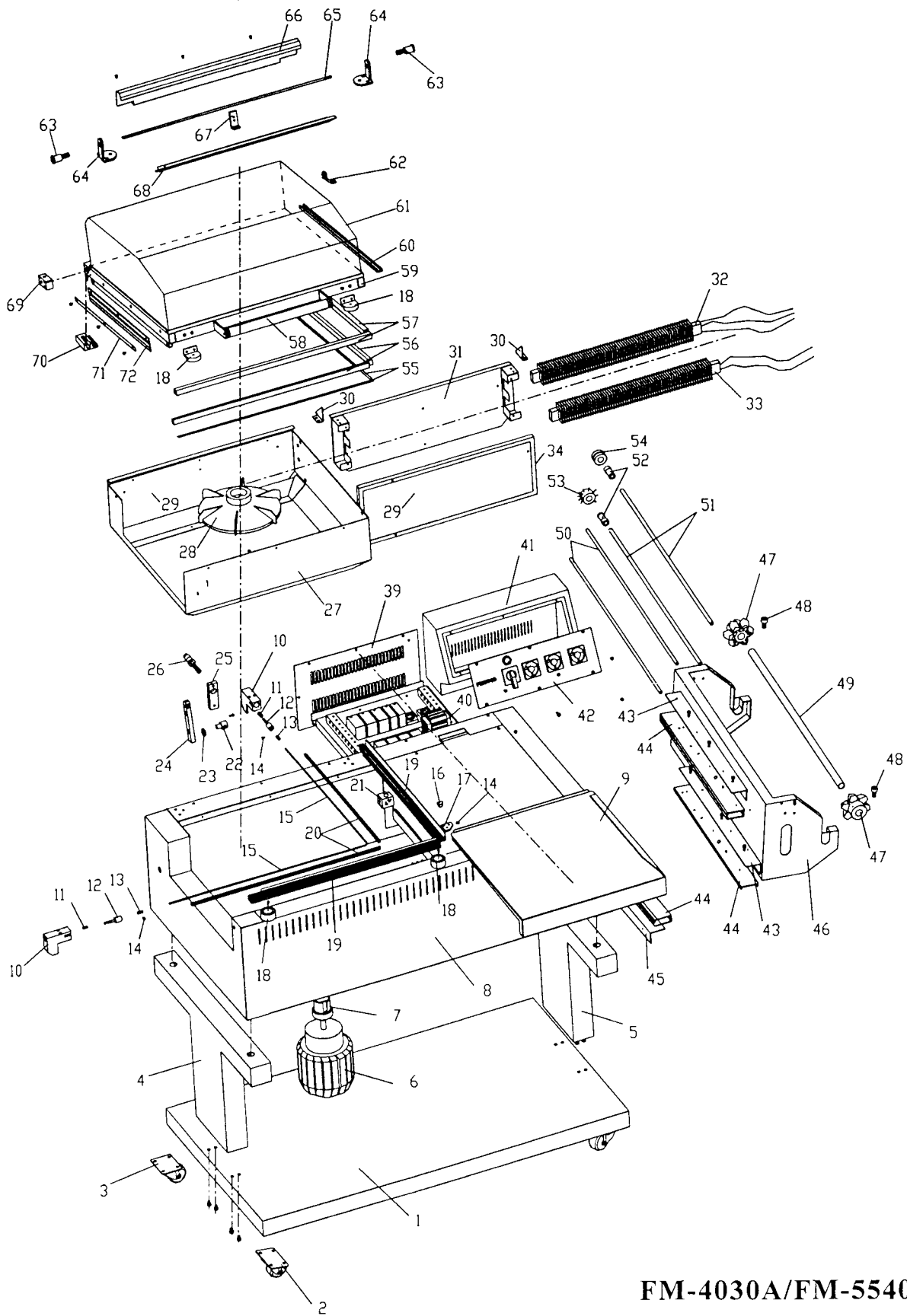

FM-4030A/FM-5540A

No.	Name	Quantity	No.	Name	Quantity
01	Baseplate	1	32	Heating tube (with thermocouple)	1
02	Wheel (with lock)	2	33	Heating tube	1
03	Wheel	2	34	Heat insulation board	1
04	Left stand	1	39	Cover board of power distributing box	1
05	Right stand	1	40	Power distributing board	1
06	Blowing motor	1	41	Control box	1
07	The cover of the blowing fan shaft	1	42	Control panel	1
08	Main frame	1	43	Skid rail 1 for angle iron installation	2
09	Movable working table	1	44	Skid rail	2
10	The support of the blade clamp	2	45	Skid rail 2 for angle iron installation	2
11	The spring of the blade clamp	2	46	Reel holder	1
12	The cooper core of the blade clamp	2	47	Fixer	2
13	The iron core of the blade clamp	2	48	Fixing bolt for the fixer	2
14	The fixing bolt of the blade clamp	3	49	Shaft of reel	1
15	Sealing blade	1	50	Shaft for film stretching ahead	2
16	The corner of the blade clamp	1	51	Shaft of perforator	2
17	The corner pad of the blade clamp	1	52	Cover of the perforator wheel	2
18	Magnet	2	53	Pin wheel of the perforator	1
19	Ceramic grain base	2	54	Slot wheel of the perforator	1
20	Ceramic blade slot	2	55	Teflon belt	2
21	Jiggle switch	1	56	Neoprene rubber	4
22	The nut for adjusting the swing angle of the torsion bar	1	57	Slot of neoprene rubber	5
23	The retaining ring for adjusting the swing angle of the torsion bar	1	58	Handle	1
24	Adjusting pendulum of the torsion bar	1	59	Upper sealing frame	1
25	Adjusting base of the swing angle of the torsion bar	1	60	Aluminium slot for fixing the glass hood.	4
26	Adjusting bar of the swing angle of the torsion bar	1	61	Glass hood	1
27	Fan box	1	62	Press plate of the jiggle switch	1
28	Blowing fan	1	63	Hollow screw	2
29	Heat insulation cotton	2	64	Support plate of the torsion bar	2 pairs, symmetrical each other
30	The support of the left and right corners of the upper sealing frame	2 pairs, symmetrical each other	65	Torsion bar	1
31	The bracket of the heating tube	1	66	Secure cover of the torsion bar	1

No.	Name	Quantity	No.	Name	Quantity
67	The press plate of the open and close board	1	82	Roller	13
68	The open and close board	1	83	Board of extended stand	1
69	Fixer of the torsion bar	1	84	Extended stand	1
70	Restrictor of upper sealing	1	85	Conveying motor	1
71	The fixing shaft of the heat-proof curtain	1	86	Motor fixing board	1
72	Heat-proof curtain	1	87	Rear girder of the transportation system	1
73	Adjusting handle	1	88	Net wheel	2
74	Rise-and-fall stand fixer 1	1	89	Cover of the main transmission shaft	1
75	Rise-and-fall screw	1	90	Main transmission shaft	1
76	Base of rise-and-fall shank 1	1	91	Front girder of the transportation system	1
77	Rise-and-fall rail	2 pairs, symmetrical each other	92	Upper wind board	1
78	Base of rise-and-fall shank 2	1	93	Conveying net	1
79	Rise-and-fall stand fixer 1	1	94	Directing pole	4
80	Angle iron of rise-and-fall directing	2 pairs, symmetrical each other	95	Idler wheel of following transmission shaft	4
81	Lower wind board	1	96	Following transmission shaft	1

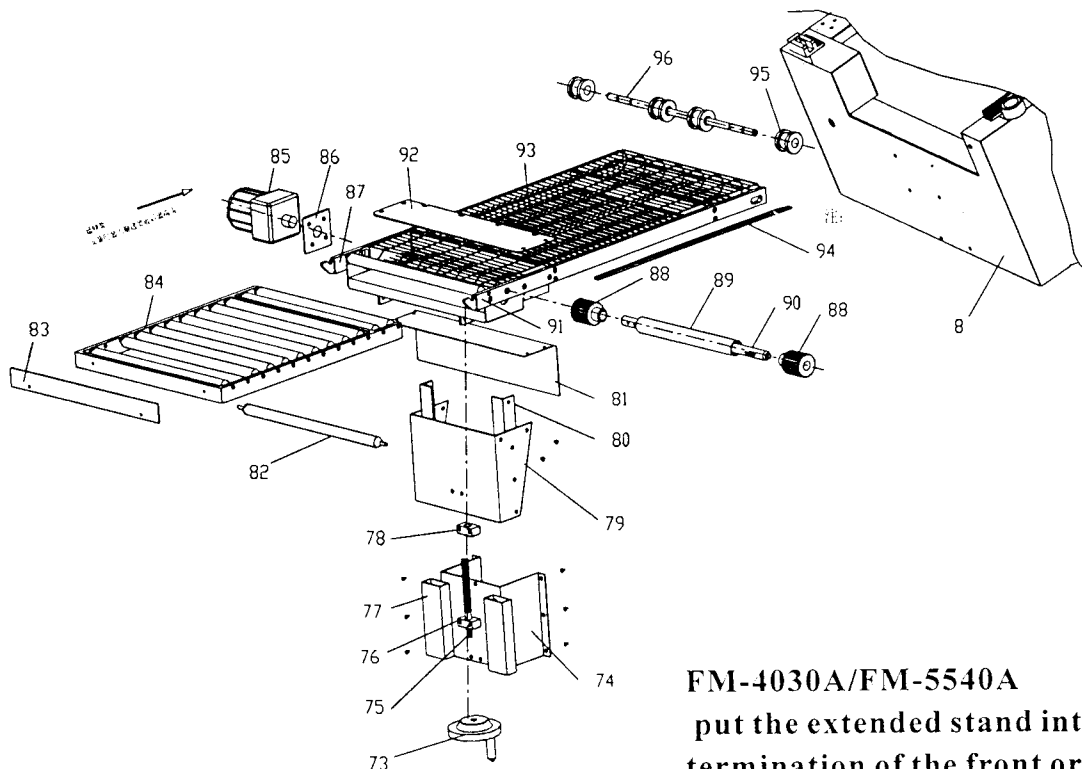

FM-4030A/FM-5540A

put the extended stand into the termination of the front or rear girder of the transportation system

Illustration of power distributing board

FM-4030/FM-5540

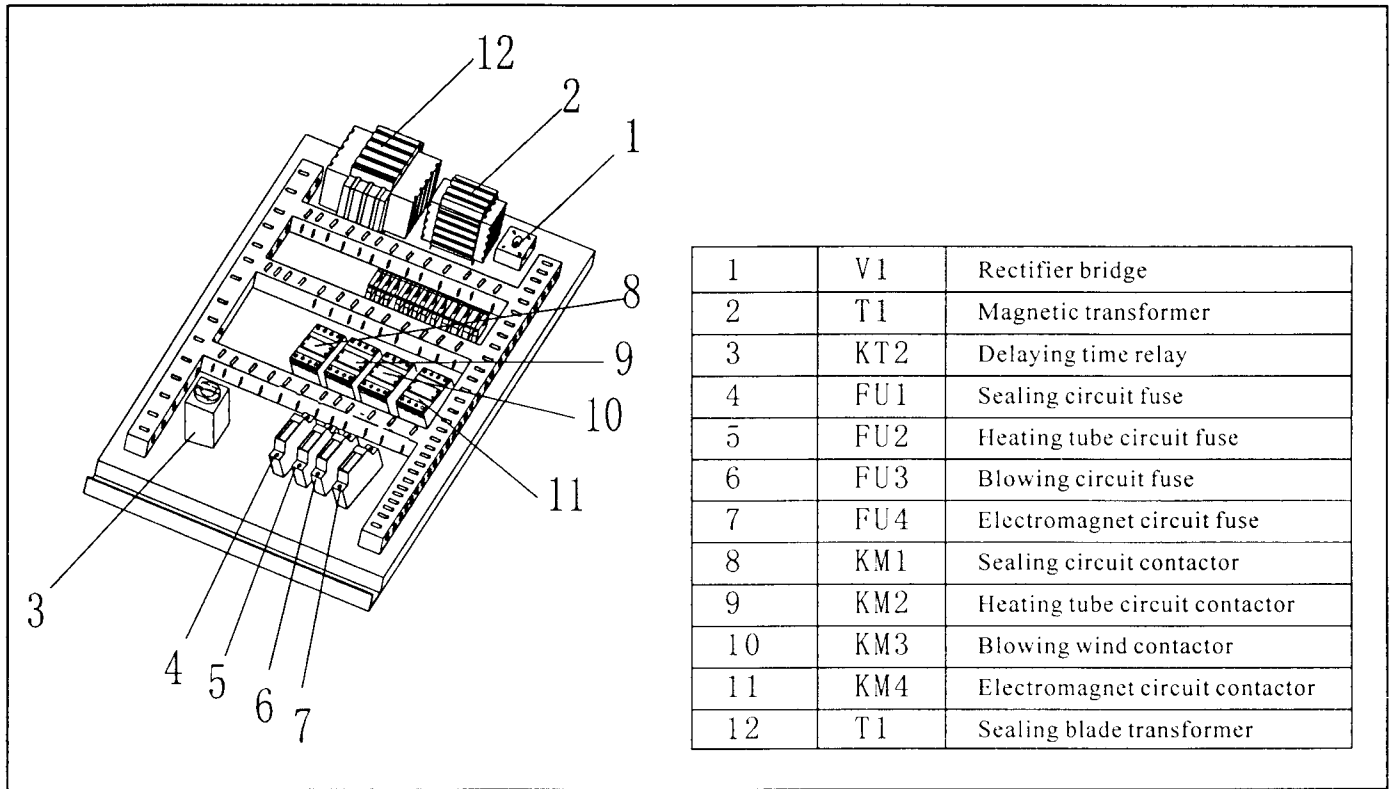

FM/4030A/FM-5540A

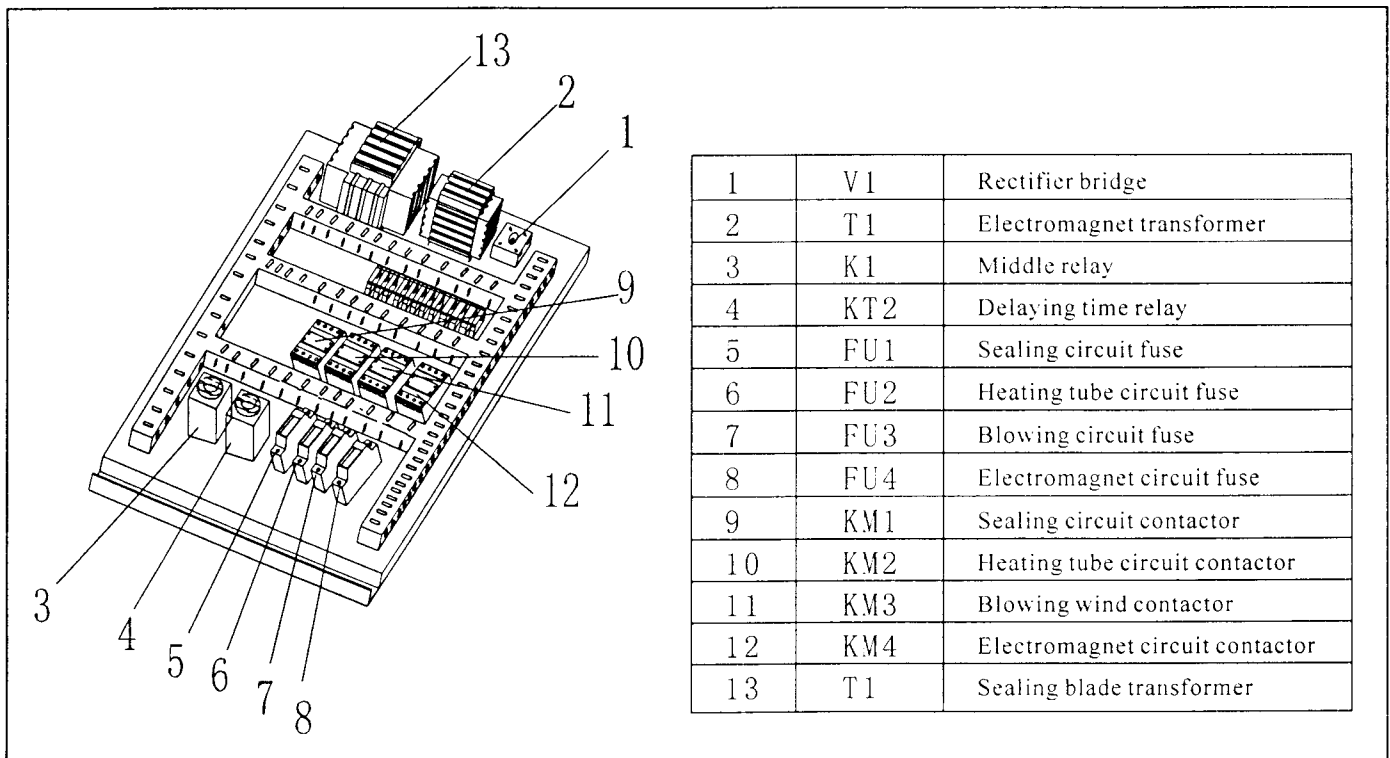

5. Machine technology parameter

Model	Powr supply	Power	Maximum sealing demission	Maximum packing demission	Weight
FM-4030	1 phase 220V 50/60Hz 1 phase 110V 50/60Hz	3.8KW	L400*W300	L400*W300*H200	100kg
FM-4030A	1 phase 220V 50/60Hz 1 phase 110V 50/60Hz	4.0KW	L400*W300	L400*W300*H200	110kg
FM-5540	1 phase 220V 50/60Hz 1 phase 110V 50/60Hz	4.0KW	L550*W400	L550*W400*H300	125kg
FM-5540A	1 phase 220V 50/60Hz 1 phase 110V 50/60Hz	4.2KW	L550*W400	L550*W400*H300	135kg

6. Machine installation

- A) Remove the upper cover board of the crate and the four side boards, unpacking the crate.
- B) Place the machine on the plain ground steadily.
- C) Unpack the protective film wrapping on the machine and parts.
- D) Install the four wheels at the bottom of the base plate in turn, the one with lock installed in the front.
- E) Install the two stands on the left and right part of the base plate in turn, fastening the screws.
- F) Put the main body of the machine on the stands. (Notice: make the four iron bolt on the main body of the machine exactly into the four holes on the stands.)
- G) The movable rail on the reel holder corresponds to the movable rail on the right side of the machine body, adjusting and making the reel holder in. (Notice: some users would like to hang the reel holder up on the machine, if so, please screw off the screws on the right side of the machine body, hanging the reel holder up and fastening the screws.)
- H) Be sure that the power supply used corresponds to that showed on the nameplate at the rear of the machine. Notice: the machine must be earthed.
- There are two kinds of power supply for the machine:
- 1 phase 110V 50Hz
 - 1 phase 220V 60Hz

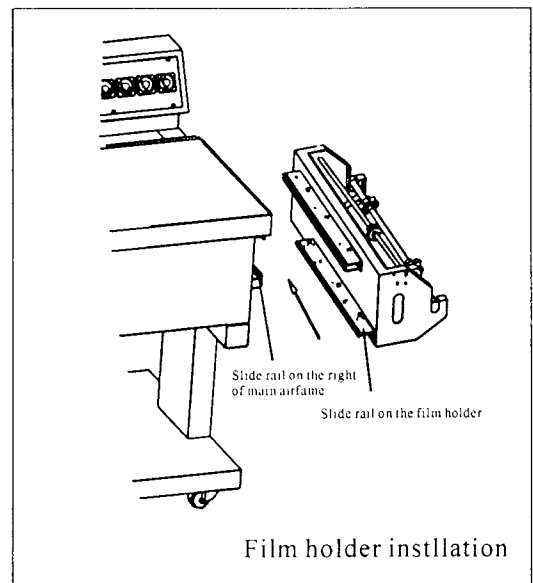
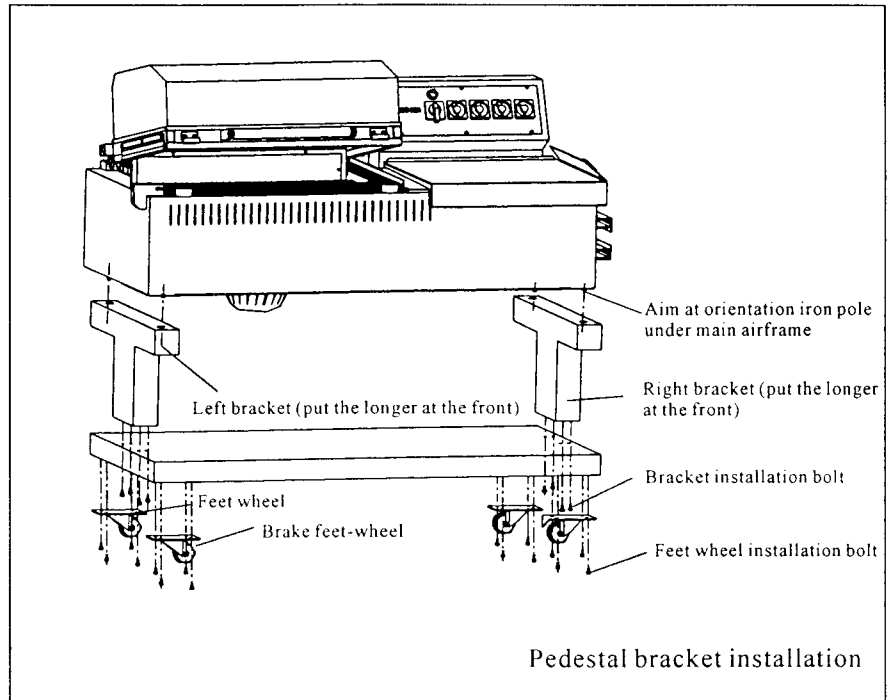

7. Machine operation method

- A) Turn the power on, adjusting the shrinking temperature according to the characteristics and thickness of the shrink film, 300°C-350°C in general.
- B) Set the sealing time according to the thickness and characteristics of the shrink film, 0.8-1.5 second in general.
- C) Usually, set the sealing time a little longer when turn the power on due to there is no any accumulation of the heat in the blade. Set the sealing time a little shorter than beginning due to the accumulation of the heat in the blade.
- D) FM-4030A or FM-5540A has automatic transportation system. Set the transporting time according to the size of the product to be packed and the specific requirements for packing.
- E) Thread the shaft of the reel through the film reel, move the fixer to the center of the reel and fasten the screws.

- F) If the way of hanging reel holder is the choice, directly put the film reel between the two rollers, positioning the two support and get it fastened.
- G) Put the shaft of the film reel on the reel holder, make the open side of the film toward to the operator.

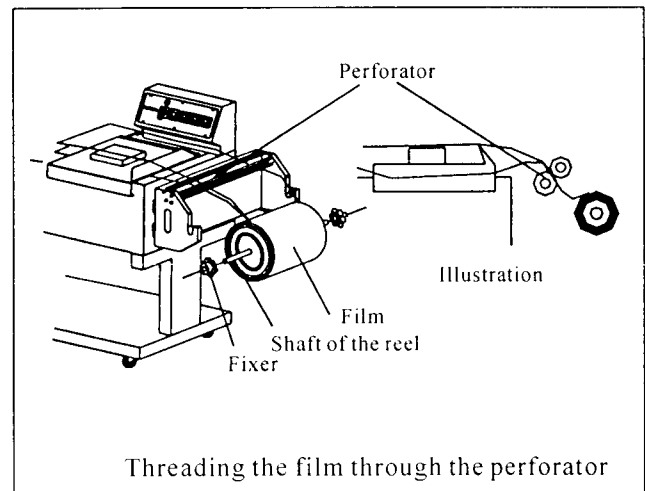

- H) Thread the film through the perforator, separate the two layers, get it surround the working table.
- I) Adjust the height of the product, parallelizing the center line of the product to be packed with the sealing blade.
- J) For FM-4030A and FM-5540A, adjust the handle which is used to adjust the height of the product according to the size of the product to be packed.

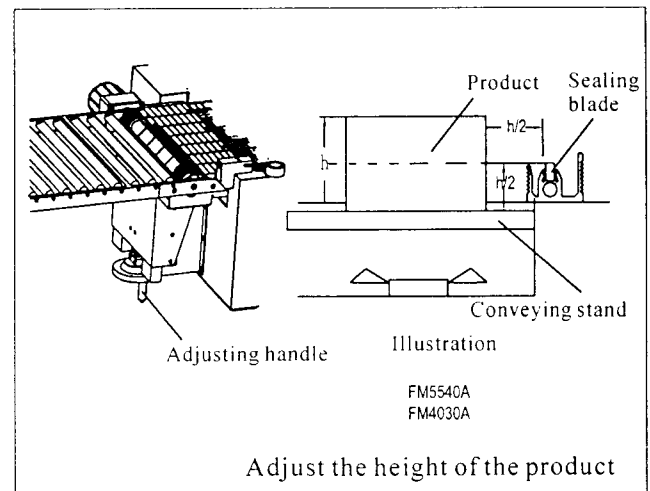

- K) Stretch the film to the sealing

area, sealing the film only.

- L) Place the product on the working table, covered by the upper sheet of the film, stretching the film and the product to the sealing area in the left.
- M) Keep a distance of $1/2$ height of the product between the product and the sealing blade in order to have enough film for shrinking.
- N) The indicator light of the temperature regulator on the control panel will turn to red when the practical temperature reach the setting value. If so, press down the chamber hood then the sealing procedure are automatically finished. Then the blowing shrinking is automatically run after 1 second's delay.
- O) The delay equipment is installed in the machine and had been set the general parameter's value well. If it needs to be reset, please ask the professional technician to do it or consult the supplier.
- P) The chamber hood jump up automatically after the blowing.
- Q) For FM-4030A and FM-5540A, after the chamber hood jumping up, the conveying system work subsequently, transporting and unloading the product.

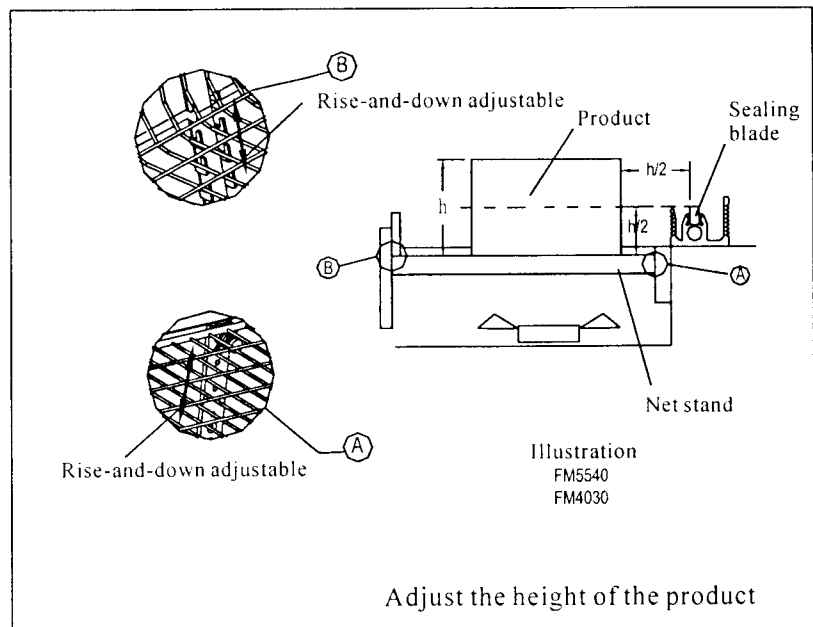

8. Machine maintenance

- A) Clean the working table, shrinking chamber and the transporting belt after the use every day.
- B) Clean the sealing blade periodically. Notice: Clean the sealing blade by a piece of dry cotton with the release agent. Don't use any metal article scratch the sealing blade.
- C) The movable parts (such as transmitting chains, bearing base) needs to be oiled with lubricant often.
- D) The sealing blade, Teflon belt, Neoprene rubber must be kept well. If the sealing blade or the Teflon is worn or damaged, replace it with a new one soon.
- E) Turn the power off before repairing, let professional to do it.
- F) The procedures of replacing the sealing blade:
 - (1) Unfasten the hexangular screws on the blade clamp, take the worn sealing blade out.
 - (2) Put one end of the new sealing blade into the slot of the blade clamp, push the screw on the top of the blade clamp by a tough tool in order to make it unmovable, then tighten the hexangular screws for fixing the sealing blade.
 - (3) Put the sealing blade into the ceramic blade slot lightly, then put the other end of the sealing blade into the slot of the other blade clamp.
 - (4) Push the screw on the top of the blade clamp by a tough tool in order to make it unmovable, then tighten the hexangular screws for fixing the sealing blade.
 - (5) End.

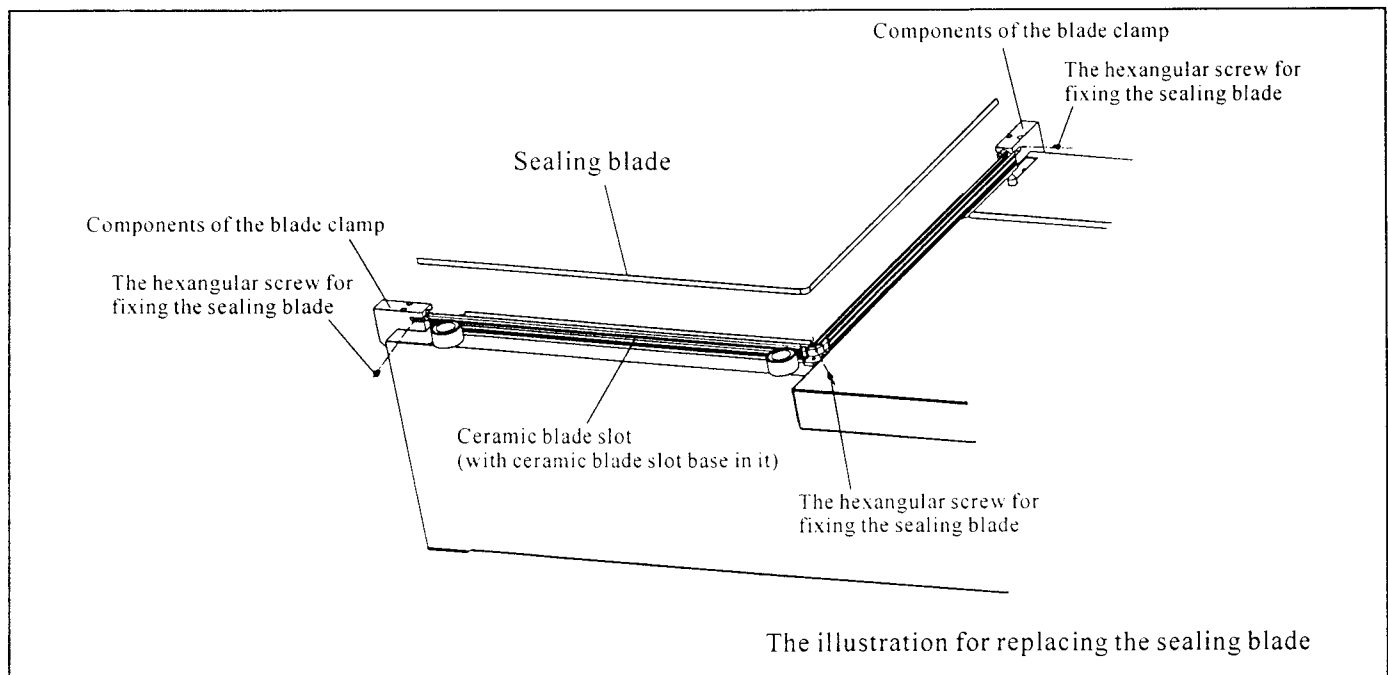

9. Machine circuit diagram

